

effiSharp – power

LED Pattern projector by EFFILUX



EFFI-Sharp Power is a range of LED lighting devices using optical properties from the original EFFI-Sharp range with 2.5 times more light emitted.

EFFI-Sharp Power lighting systems provide a powerful and focused beam. It projects full patterns with sharp edges such as square or circle to illuminate objects at long working distances, up to 1 m.

It is distinguished by its high optical power, high homogeneity and high scalability. It sets optimal conditions for high-contrast inspection work.

EFFI-Sharp Power is a LED spotlight for localized illumination and is ideally designed for long distance projection and high-contrast applications.

EFFI-Sharp Power is a durable LED light source that offers a service life of up to 60,000 hours. The device is available in different visible colors and in UV.

BENEFITS

High intensity lighting

Highly uniform illumination

Easy installation

- No ocular hazards
- Compactness
- Few maintenance : very long lifetime

Flexible

- Adjustable working distance :
 - o from 100 mm to 2500 mm
- Adjustable targeted area :
 - o from 100 mm² to 1 m²
- Any kind of pattern available:
 - o Circle, square...
- Full range of color from UV to Deep red
- White color
- Wide dimming range of 0-100%

Applications:

- Pick and place
- Defect inspection
- Micro defect detection
- Quality control of black products with low diffusion properties
- High speed quality control
- Reduced space applications

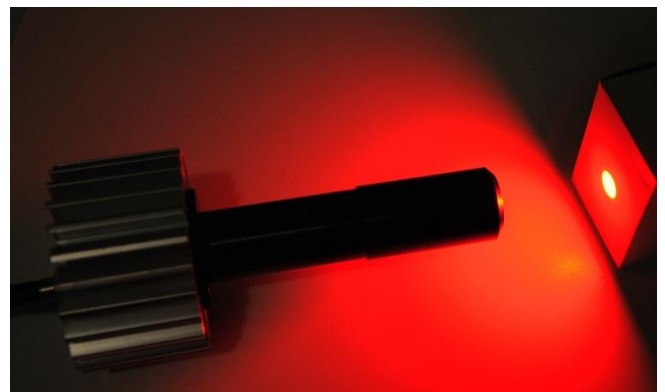

Efficient
Led Lighting
effiLUX

EFFI-Sharp Power devices:

The following data are obtained with a white EFFI-Sharp Power and a rounded pattern.

- EFFI-Sharp Power NF
 - Near field projection
 - 80 000 lux at 150 mm
- EFFI-Sharp Power MF
 - Middle field projection
 - 6 000 lux at 500 mm
- EFFI-Sharp Power FF
 - Far field projection
 - 3000 lux at 1 000 mm

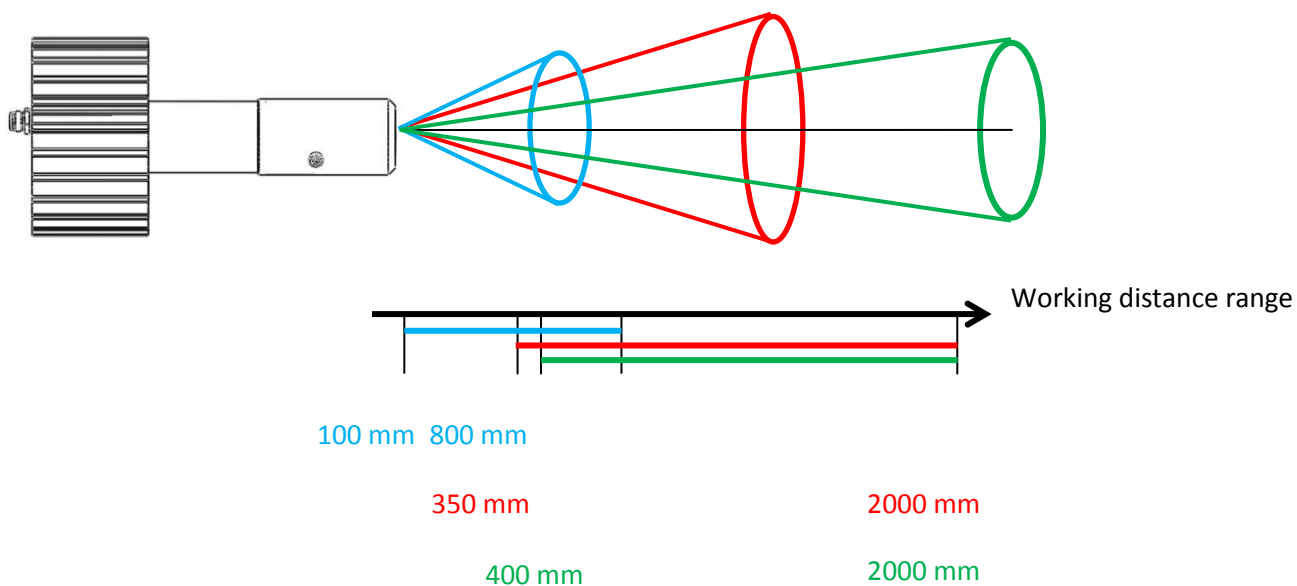

Product nomenclature



XX	XXX	X
Working distance range	Wavelength (nm)	Pattern
NF: Near Field	Cool White: 000	1: Square
MF: Middle Field	Neutral White: 001	2: Circle
FF: Far Field	Warm White: 002	3: Crescent-shaped
	Available colors (*)	

Available colors (*)

365: UV
 400: Near UV
 460: Blue
 525: Green
 590: Amber
 625: Red
 660: Deep Red

Other colors are available upon request.

Projection pattern (all dimensions are expressed in millimeters)

Standard patterns

Circle

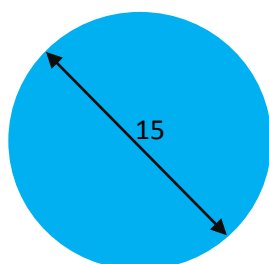

Square

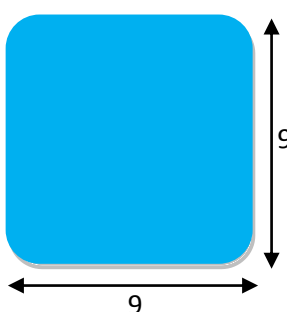

Crescent-shaped

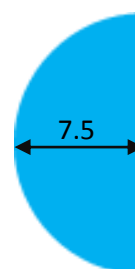

Custom-made patterns

Custom-made patterns suitable for specific needs can be supplied upon request.

Optical Characteristics

All measurements have been made with a rounded pattern.

Uniformity of the light

Uniformity of the light field of a circle projection with an EFFI-Sharp Power MF

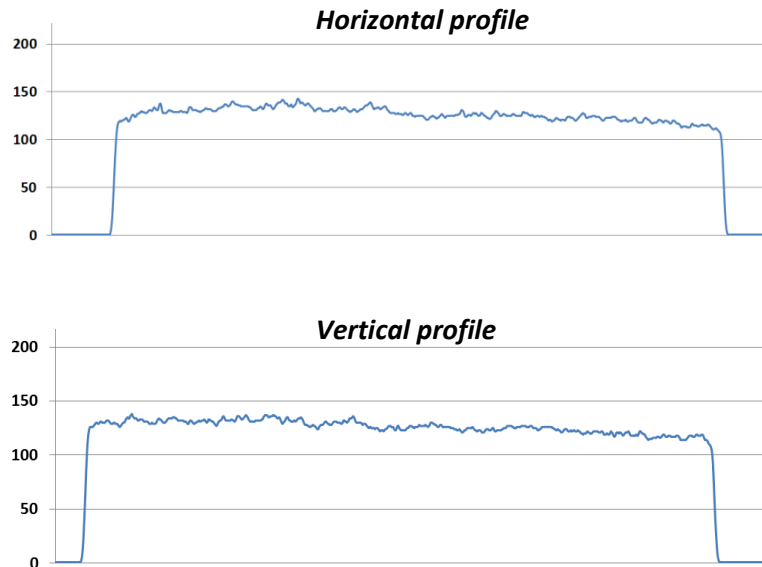
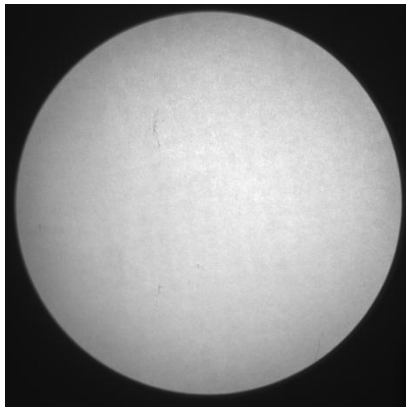

LED typical Spectrum

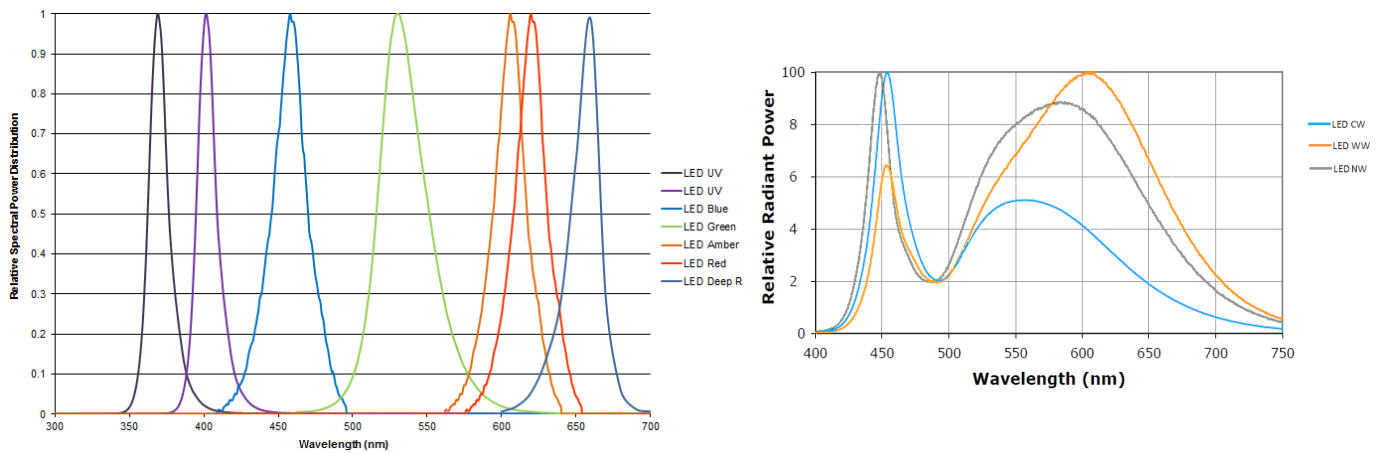

Other wavelengths are available upon request.

Evolution of the pattern size with the working distance

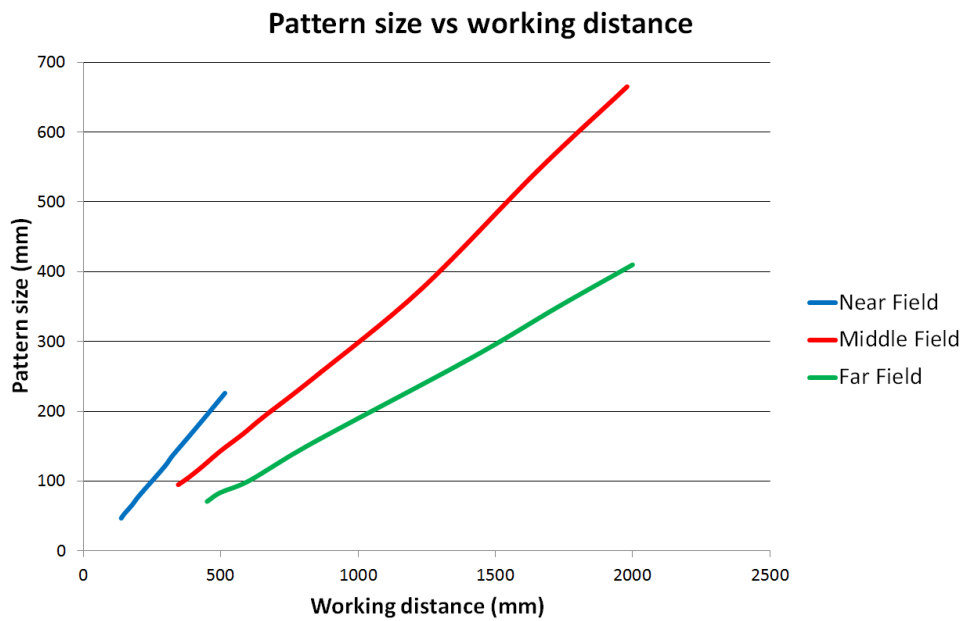

Evolution of the illuminance with the working distance

Measurements have been made with a rounded pattern.

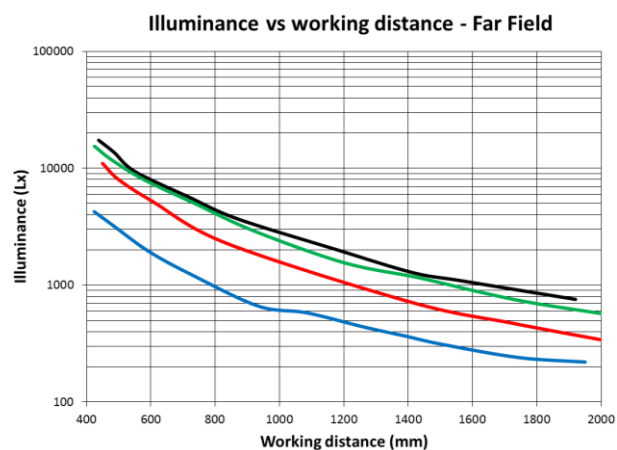
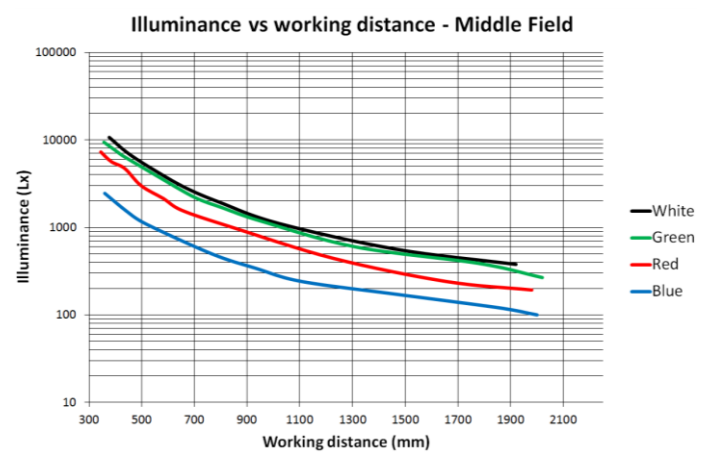
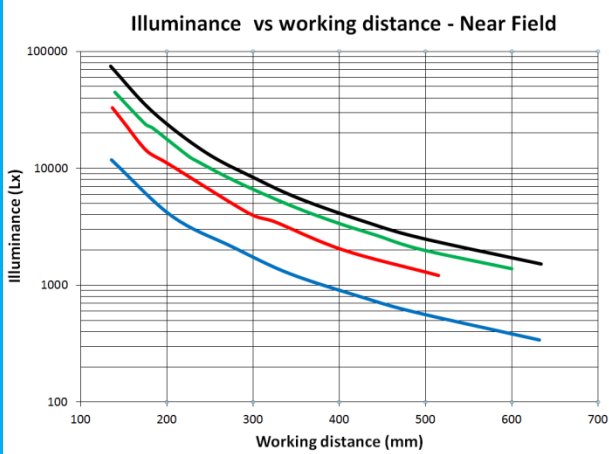

Electrical characteristics

Two options are offered to supply an EFFI-Sharp Power:

1. Use an EFFI-Supply Wire (Supplied by Effilux)
2. Use a direct current source

Warning:

Changes or modifications not expressly approved by Effilux could void the user's authority to operate this device: use only the proper type of power supply and never exceeds the maximum ampere rate.

This device should be operated from the type of power indicated on the marking label. If you are not sure of the type of power available, use the EFFI-Supply Wire.

EFFI-Supply Wire

EFFI-Supply Wire converts the input voltage into constant current, used to drive the high power LEDs. EFFI-Supply Wire is specially designed for a high current level stability and an analogue voltage dimming.



EFFI-Supply Wire

Electrical considerations

Pin	1	2	3	4
Identification	24VDC	n.c.	GND	DIM.
Wire color	Brown	White	Blue	Black

EFFI-Supply Wire

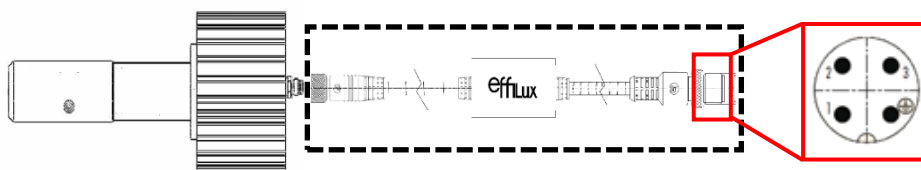

E-FFI Supply Wire presentation

<i>Model</i>	<i>EFFI-Supply Wire 0.7</i>
Input voltage	24 VDC (±10 %)
Power consumption	See section 'LED Power Ratings'
Intensity control	Current control system
Forward current	700 mA
ON / OFF Time	300 μs
Maximum Dimming Frequency	300 Hz
Operating environment	Temp. : 0 to 40 °C, humidity : 10 to 90 %RH

Dimming control

EFF- Sharp Power can be dimmed by an analogue voltage. If the dimming control is not used, leave the pin opens.

Input Voltage Range:		0.3V to 15V
Control Voltage Range Limits:	Full On	0.13V ± 50mV
(see Graph)	Full Off	4.5V ± 50mV
Analogue Current :		V_c=5V 0.2mA max.

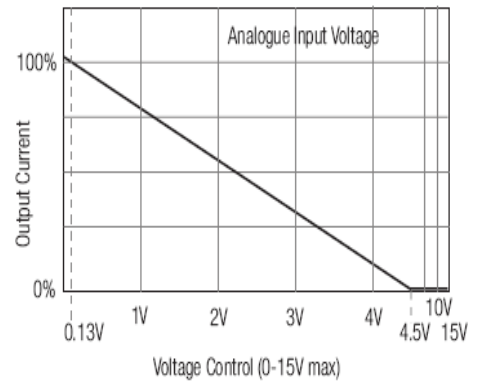

Connection example



Supply with a current source



A current source, with the correct settings and the correct wires, can be used to supply EFFI-Sharp Power: details can be found in the following table and pictures.

To pulse and/or to strobe at high frequency the EFFI-Sharp Power, use an appropriate current source.

Direct current Source

Input voltage	See the section "LED Power Ratings"
Power consumption	See "LED Power rating"
Maximum continuous forward current	1000 mA
Peak pulsed forward current	1800 mA
Maximum flash frequency	1 MHz
Maximum strobe pulse width	50 µs

Wires connections for direct LED control

M8, 3 pins.

Reference: 79-3406-42-03

Manufacturer :  binder USA

SERIES 718

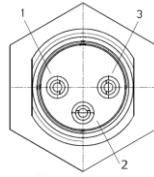

Pin	1	2	3
Terminal	Anode (A)	Cathode (K)	n.a.
Sign	+	-	n.a.
Wire color	Blue	Black	n.a.

Connection example



LED Power Ratings

Products	Wavelength peak	Forward voltage (Volt)	Forward current (mA)
EFFI-Sharp Power WHITE	n.a.	14	700
EFFI-Sharp Power NUV	365 nm	16.4	700
EFFI-Sharp Power UV	400 nm	15.6	700
EFFI-Sharp Power BLUE	460 nm	14	700
EFFI-Sharp Power GREEN	525 nm	15	700
EFFI-Sharp Power AMBER	590 nm	9	700
EFFI-Sharp Power RED	625 nm	9	700
EFFI-Sharp Power DEEP RED	660 nm	10.5	700

Thermal Characteristics

EFFI-Sharp Power design enables the heat transfer from the LED p-n junction in order to obtain high performances and a long lifetime.

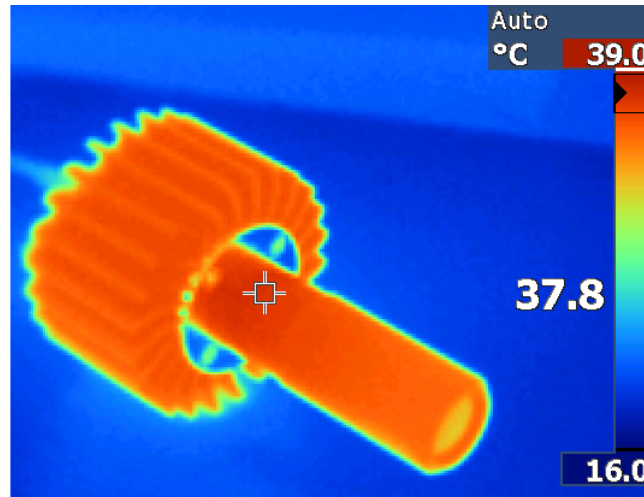

Mechanical Characteristics (all dimensions are expressed in millimeters)

Dimensions

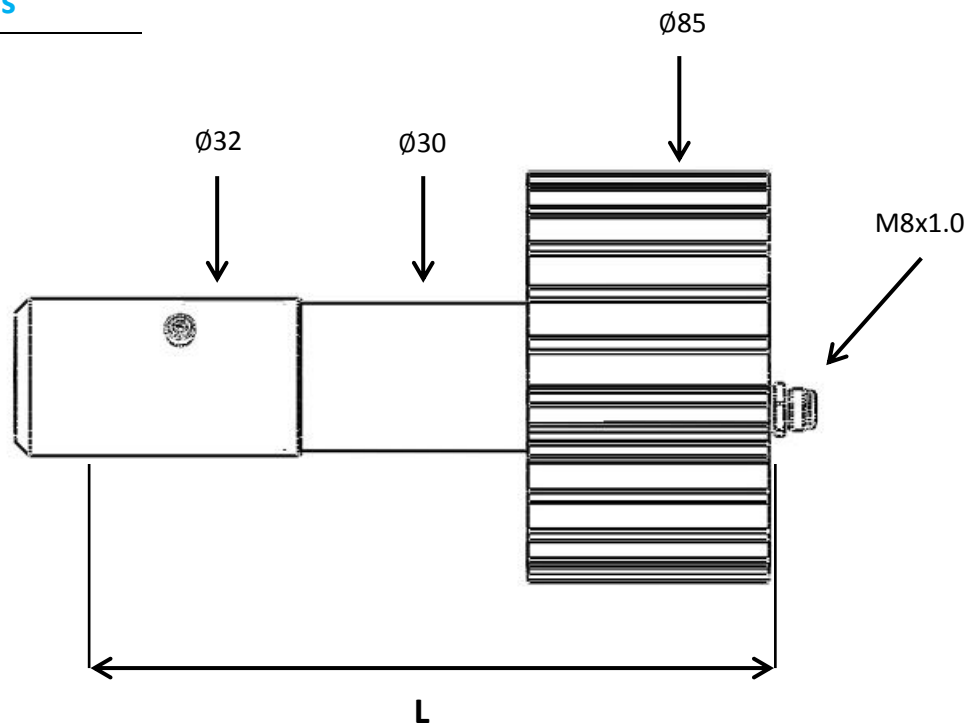

EFFI-Sharp Power	NF	MF	FF
Min L	135	140	157
Max L	145	157	191

Focusing adjustment

A sharp image is obtained by turning the device's ring in one or another direction until the image is in focus.

Fastener

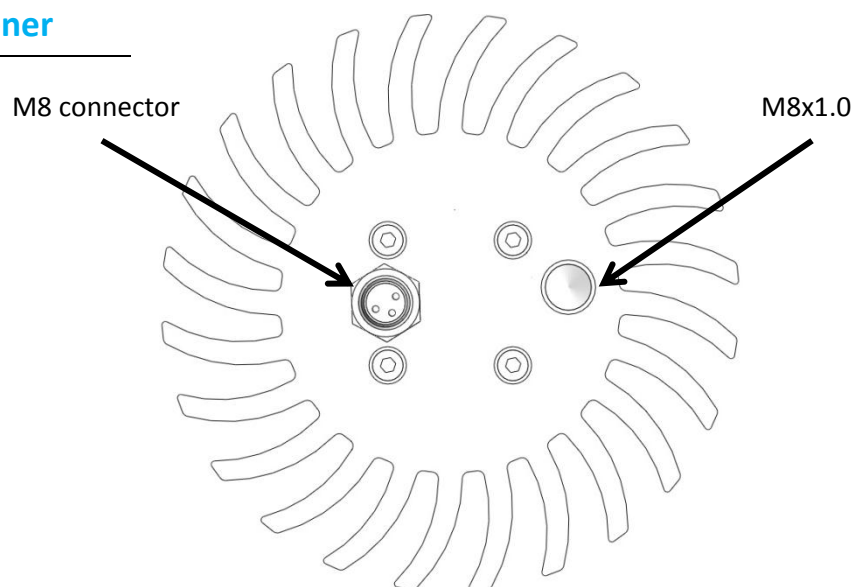

Bill of materials

➤ **EFFI-Supply-Wire_M12/M8_700_300**

- Input connector M12
- Output connector M8
- Size 300 mm
- Input Power 24 Volt, 20 Watts
- Output Power 700 mA



Accessories

Other Wires

➤ **EFFI-Wire_M8_3_2000_angled**

- Wire gauge (mm²) 0,25 mm²
- Wire gauge (AWG) 24
- Cable length 2 m



➤ **EFFI-Wire_M8_3_2000**

- Wire gauge (mm²) : 0,25 mm²
- Wire gauge (AWG) : 24
- Cable length: 2 m



➤ **EFFI-Wire_M12_4_1000**

- Wire gauge (mm²) 0,2
- Wire gauge (AWG) 24
- Cable length 1 m

Optical accessories

➤ EFFI-Coaxial

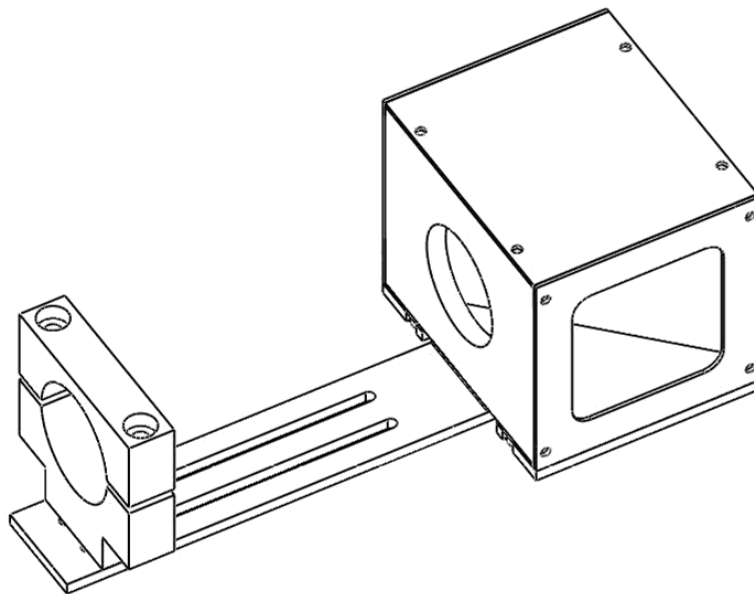

Open the clamp in part 1 and place the projector body in it.
Close and tighten the clamp with two M4 screws.

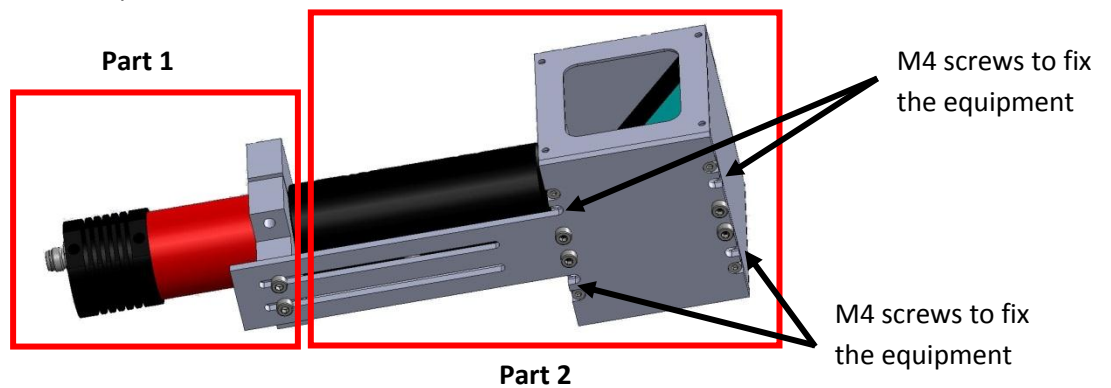

Use the holes in part 2 to fix the equipment in your setups.

➤ **EFFI-Bride**

This accessory is provided to simplify the integration of the device in your setups.

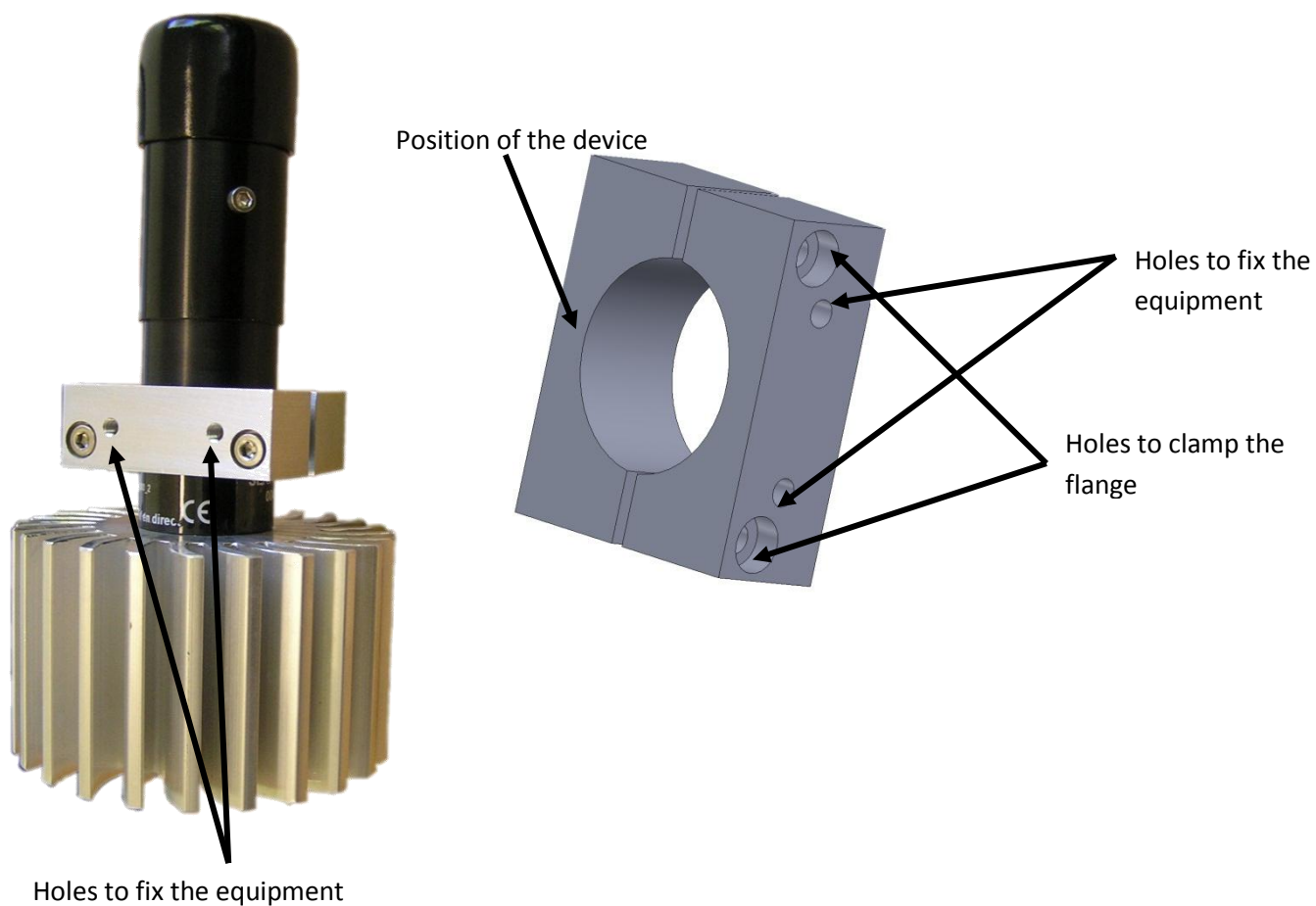

Insert the body of the device in between the 2 parts of the clamp.

Combine the two parts of the clamp with two M4 screws.

Use the two remaining holes to fix the equipment to your setup: use two M4 screws.

➤ **EFFI-Rot-M4**

This accessory is provided to simplify the integration of the device in your setups: using this system, you can easily adjust the orientation of your projector.

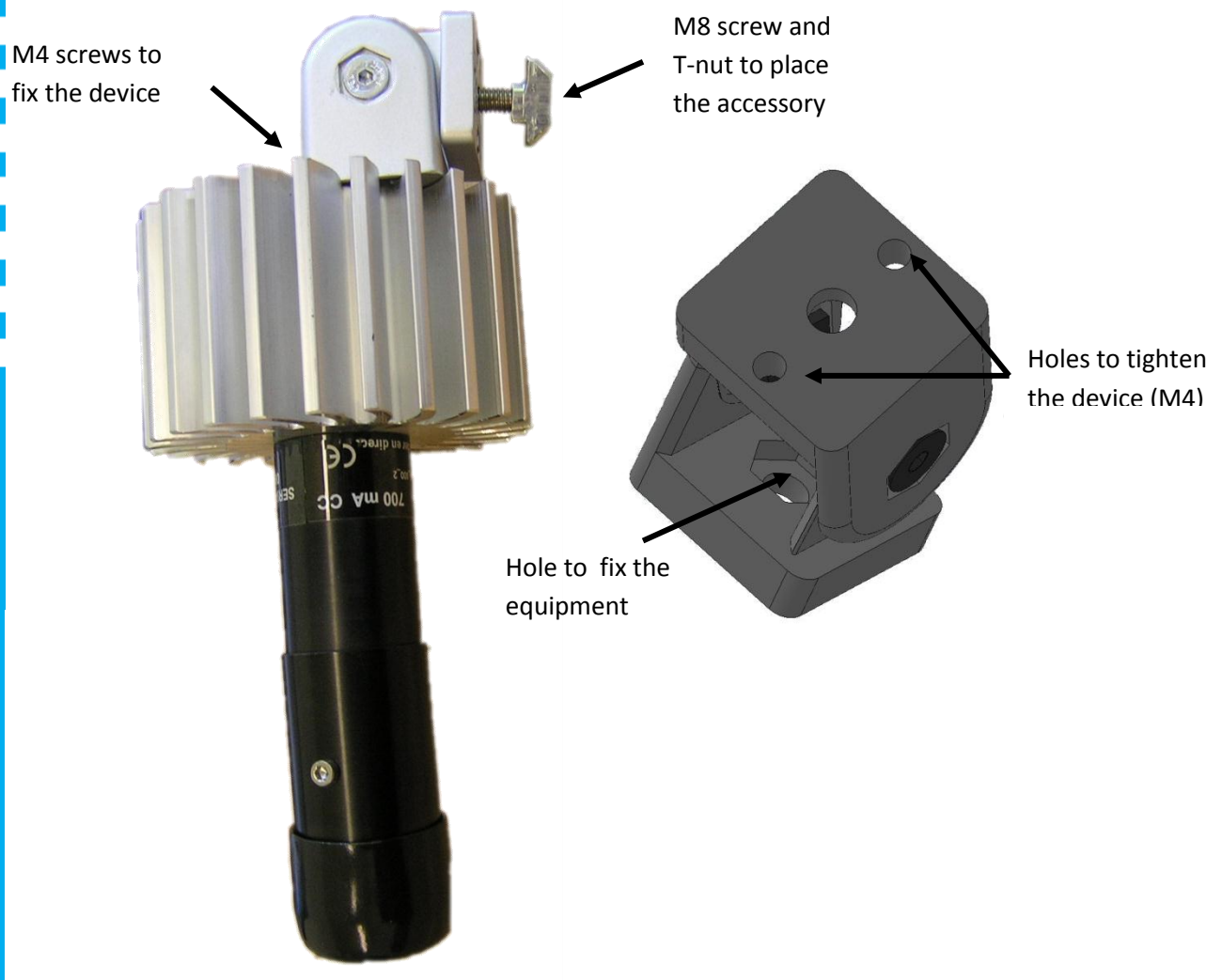

It is recommended to use the combination of a M8 screw and a T-nut to safely fix your equipment.

➤ **EFFI-Angle90**

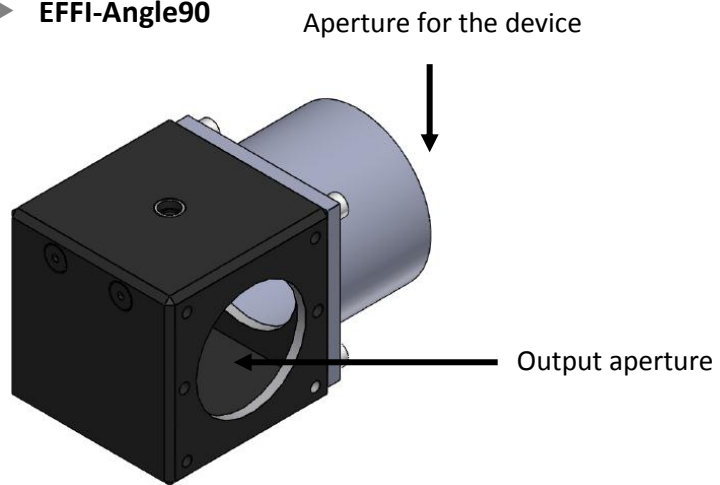

Insert the projection head of the device in the dedicated aperture. Slide the device until stop.
Use the 2 screws on the sides of the accessory to maintain the projector.